

# HIGH VOLTAGE CONTACTORS ECK200 SERIES

## INTRODUCTION

ECK200 series high-voltage DC contactor is designed for control in new energy applications. The ECK200 product line is an innovative and reliable solution for EV charging stations, solar inverters, battery energy storage systems, automated-guided vehicles (AGV) and e-Forklifts. ECK200 is hermetically sealed with ceramic technology and enable high switching capability under 1000VDC. The built-in PWM module design makes it smaller to save space.

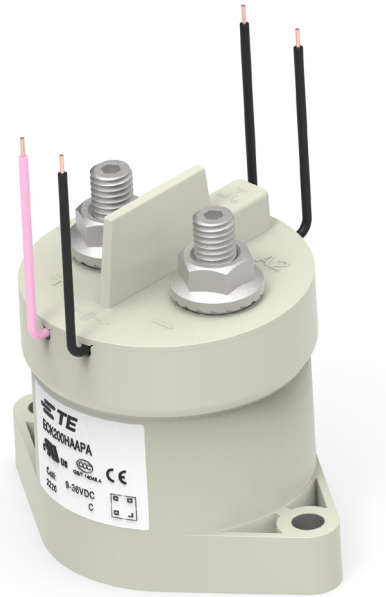

## FEATURES

- Hermetically sealed with ceramic technology.
- Designed with built-in economizer, hold power 1.7W.
- 500A carry current capability (see cautions).
- Maximum DC breaking current at 2000A.
- Maximum DC breaking voltage at 1000VDC.
- Auxiliary contact version available.
- Comply with DC-1 utilization category in IEC60947-4-1 .

## APPLICATIONS

- DC Charging station
- Electric vehicle
- AGV
- Electric forklift
- Energy storage systems
- Photovoltaic inverter
- DC converter
- Battery protection board

## APPROVALS

- CCC: 2022960304002220
- CE: 724-00004
- UL: E82292



# High Voltage Contactors ECK200 Series

## CONTACT DATA

Continuous carry current	500A
Rated switching current	200A
Max. Switching voltage	1000VDC
Contact arrangement	1 Form X (SPST-NO-DM)
Initial voltage drop	≤ 0.4mΩ (200A, after 1 minute)
Operate time, max. (At 23°C)	30ms
Release time, max. (At 23°C)	10ms
Mechanical life	500,000 cycles

## CONTACT RATINGS

Load	Cycles
200A, 450VDC, make/break, resistive	6000
200A, 1000VDC, make/break, resistive	1000
600A making, resistive	6000

## OTHER DATA

Material compliance:EU RoHS/ELV, China RoHS, REACH, Halogen content refer to the product Compliance Support Center at <a href="http://www.te.com/customersupport/rohssupportcenter">www.te.com/customersupport/rohssupportcenter</a>	
Ambient temperature	-40°C to 85°C
Vibration resistance (functional)	Sine, 10-2000Hz, 4.5G
Shock resistance (functional)	11ms 1/2 Sine, Peak 20G
Terminal type	Screw for contact, wire for coil
Weight	380g
Packaging/Unit	Box/24 pcs.

## COIL VERSIONS, DC COIL

Coil Code	Nominal Voltage	Nominal Operate Current	Max Starting Current	Operate Voltage	Maximum Operate Voltage	Release Voltage	Coil Power
A	9-36VDC	0.13A@12VDC 0.07A@24VDC	3.6A	≤9VDC	36VDC	≥3VDC	Start: 43.2W Hold: 1.7W

All figures are given for coil without pre-energization, at ambient temperature +23°C.

## CE DECLARATION (IEC60947-4-1)

Rated Operational Current	Utilization Category	Switching Cycles
100A	DC-1	6,050

## AUXILIARY CONTACT DATA

Contact form	1 Form A (SPST-NO)
Contact current, Max.	2A, 30VDC
Contact current, Min.	10mA, 8VDC
Contact resistance, Max.	0.4Ω @ 30VDC

## INSULATION DATA

Dielectric Withstand Voltage (leakage current <1mA)	
Between open main contacts	3500Vrms
Between main contact and coil	3500Vrms
Between main contacts and aux contacts	3500Vrms
Between open aux contacts	750Vrms
Initial Insulation Resistance @ 1000VDC	
Between insulated elements	> 1x10 <sup>9</sup> Ω

# High Voltage Contactors ECK200 Series

## CURRENT CARRYING CAPABILITY CURVE

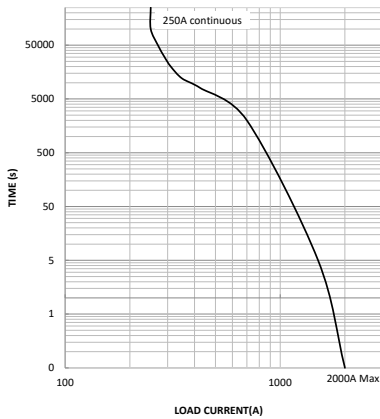

### NOTES

- The data is measured at the environment temperature 85°C with cross section area of wire 150mm<sup>2</sup> min.
- Smaller cable cross section wires are also allowed depending on the end users conditions.
- For 500A continuous carry, recommend users to select the appropriate connection cable cross section or active cooling to control the temperature.

## DIMENSIONS

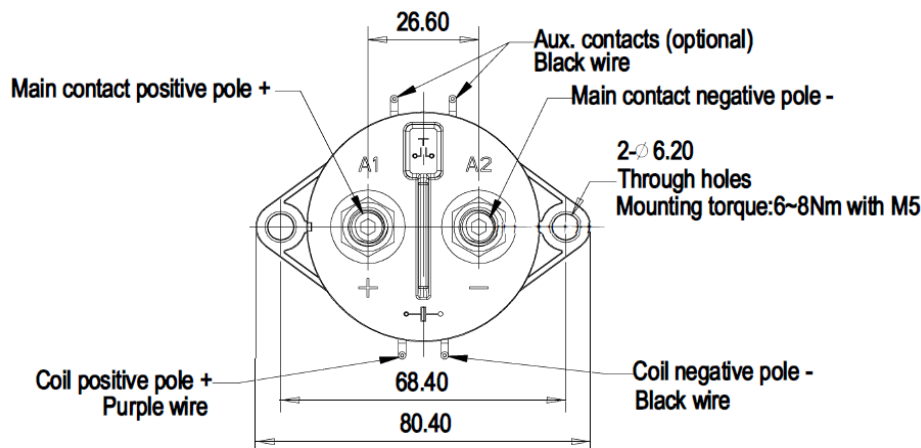
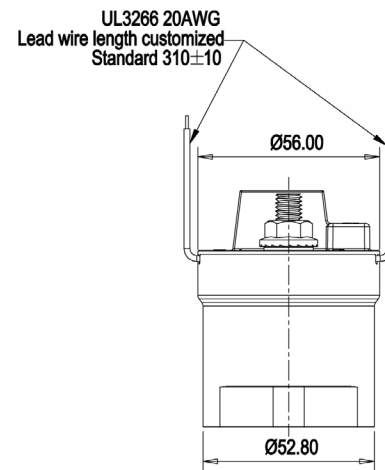
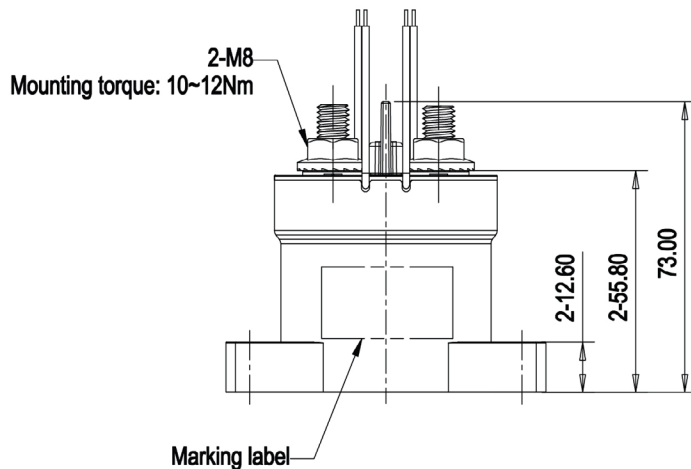

## ESTIMATED MAKE & BREAK POWER SWITCHING RATINGS

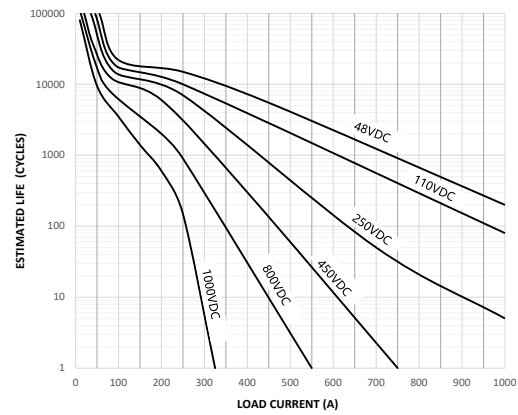

### NOTES

- The curve was created based on extrapolated data with few typical points, users are recommended to confirm performance in actual application.
- The typical data were estimated with resistive load at room temperature.

## CIRCUIT DIAGRAM

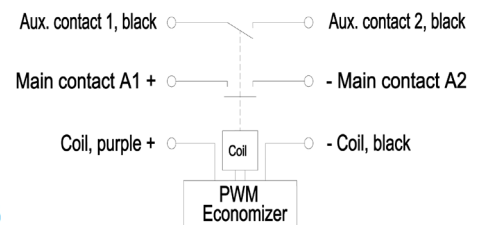

General Tolerance	
Dimension	Tolerance
<10	±0.3
10 - 50	±0.6
>50	±1.0

## ORDERING INFORMATION

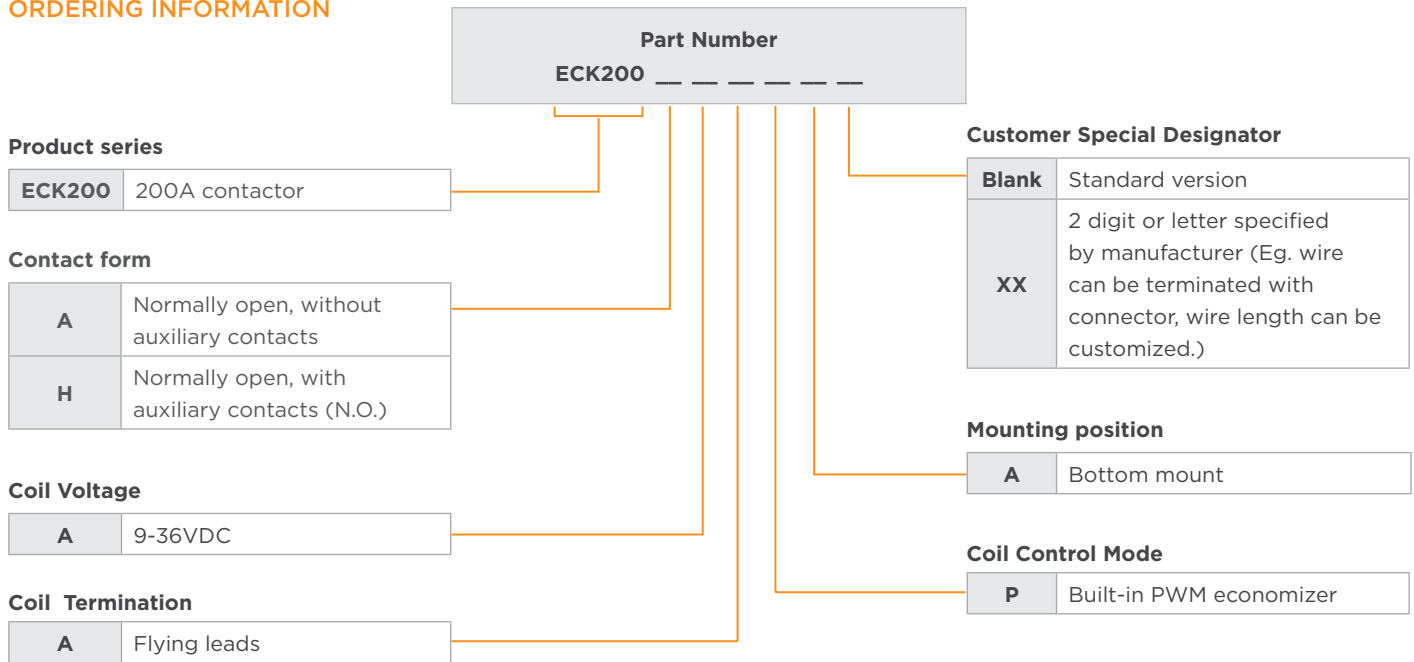

## PRODUCT PART NUMBER TABLE

Product Code	Contact Form	Mounting Position	Coil	Coil Control Mode	Part Number
ECK200AAAPA	Normally open, without auxiliary contacts	Bottom	9-36VDC	Built-in PWM economizer	<u>1-2071567-2</u>
ECK200HAAPA	Normally open, with auxiliary contacts (N.O.)				<u>1-2071567-1</u>

Note: Only typical part numbers are listed above, other types please contact TE engineer.

## CAUTIONS

- Do not use the product when product is dropped or broken.
- Avoid mounting the contactor with the main contact screw terminals in downward direction, otherwise the contactor performance will not be guaranteed.
- Please use correctly according to the mark on the surface of the product. Main contact terminals and coil wires have polarity difference. When the connection polarity is reversed, the electrical characteristics promised in the datasheet will not be guaranteed.
- If using with diodes for coil, it may lead to a decline in product switching performance.
- Please consider electromagnetic interference when using the product.
- Screw locking torque of main contact terminals should be 10-12 N·m for M8 screw. Screw locking torque of product bottom mounting should be 6-8 N·m for M5 screw.
- For continuous high carry current condition above 300A, the upper limit of the absolute temperature is 170°C, evaluated according to IEC 60695-10-2. To maintain the maximum long-term performance, user should select the appropriate connection cable cross section or active cooling to control the temperature.
- Suitable for applications under Uimp 6kV.

## te.com

©2023 TE Connectivity. All Rights Reserved.

TE Connectivity, TE Connectivity (logo) and Every Connection Counts are trademarks. All other logos, products and/or company names referred to herein might be trademarks of their respective owners.

The information given herein, including drawings, illustrations and schematics which are intended for illustration purposes only, is believed to be reliable. However, TE Connectivity makes no warranties as to its accuracy or completeness and disclaims any liability in connection with its use. TE Connectivity's obligations shall only be as set forth in TE Connectivity's Standard Terms and Conditions of Sale for this product and in no case will TE Connectivity be liable for any incidental, indirect or consequential damages arising out of the sale, resale, use or misuse of the product. Users of TE Connectivity products should make their own evaluation to determine the suitability of each such product for the specific application.

Issue Date: 03/23 ED